

**1380**
Hoftrac**Technical specifications**

	1380 P-kinematics	1380 PZ-kinematics
Engine data Standard		
Manufacturer	Perkins	Perkins
Engine type	404 D-22 de	404 D-22 de
Cylinders	4	4
Engine performance (max.) kW (hp)	31.4 (43*)	31.4 (43*)
at rpm (max.) rpm	2,600	2,600
Cubic capacity cm ³	2,216	2,216
Cooling system	Water	Water
Engine data Option		
Manufacturer	Perkins	Perkins
Engine type	404 D-22	404 D-22



	1380 P-kinematics	1380 PZ-kinematics
Cylinders	4	4
Engine performance (max.) kW (hp)	35.7 (49*)	35.7 (49*)
at rpm (max.) rpm	2,600	2,600
Cubic capacity cm ³	2,216	2,216
Cooling system	Water	Water
Electric motor		
Battery Standard		
Battery Optional		
Electrical system		
Operating voltage V	12	12
Battery Ah	77	77
Alternator A	65	65
Weights		
Operating weight (standard) kg	2740-2950	2740-2950
Tipping load with bucket - machine straight kg	1876-2071	1803-1948
Tipping load with bucket - machine articulated kg	1495-1653	1508-1657
Tipping load with pallet fork - machine straight kg	1557-1722	1534-1614
Tipping load with pallet fork - machine articulated kg	1239-1368	1270-1359
Vehicle data		
Axle (optional)	T94 (T110, PA940)	T94 (T110, PA940)
Cab (optional)	FSD (eps, cabin)	FSD (eps, cabin)
Ground speed (optional) km/h	0 - 20 (28*)	0 - 20 (28*)
Speed stages	2	2
Fuel tank capacity l	50	53
Hydraulic oil tank capacity l	30	30
Hydraulic system		
External services - Operating pressure (optional) bar	360	360
Steering hydraulics - Oil flow l/min	49.4 (58.5*)	49.4 (58.5*)
Steering hydraulics - Operating pressure bar	210	210
Drive		
Type of drive	Hydrostatic	Hydrostatic
Traction drive	Universal joint shaft	Universal joint shaft
Noise values		
Guaranteed sound power level LwA dB(A)	99.9	99.9



	1380 P-kinematics	1380 PZ-kinematics
Specified sound pressure level LpA dB(A)	82	82

Tipping load calculation according to ISO 14397 (horizontal mast)

FSD = operator's canopy

eps = Easy Protection System (fold-down operator's canopy)

Vibrations (weighted average effective value)

Hand-arm vibrations: The hand-arm vibrations are no more than 2.5 m/s²

Whole-body vibrations: This machine is equipped with a operator's seat that meets the requirements of EN ISO 7096:2000.

When the loader is properly used, the whole body vibrations vary from below 0.5 m/s² up to a short-term maximum value.

It is recommended to use the values specified in the table when calculating the vibration values according to ISO/TR 25398:2006. At the same time, the actual use conditions have to be taken into consideration.

Telehandlers, like wheel loaders, are to be classified by operating weight.

Type of loader	Typical operating conditions	Mean value			Standard deviation (s)		
		1.4*a _{w,eqx}	1.4*a _{w,eqy}	a _{w,eqz}	1.4*s _x	1.4*s _y	s _z
		[m/s ²]	[m/s ²]	[m/s ²]	[m/s ²]	[m/s ²]	[m/s ²]
Compact wheel loader (operating weight < 4,500 kg)	Load & carry (load and transport work)	0.94	0.86	0.65	0.27	0.29	0.13
Wheel loader (operating weight > 4,500 kg)	Load & carry (load and transport work)	0.84	0.81	0.52	0.23	0.2	0.14
	Application in extraction (harsh application conditions)	1.27	0.97	0.81	0.47	0.31	0.47
	Delivery drive	0.76	0.91	0.49	0.33	0.35	0.17
	V-operation	0.99	0.84	0.54	0.29	0.32	0.14

1380

Hoftrac

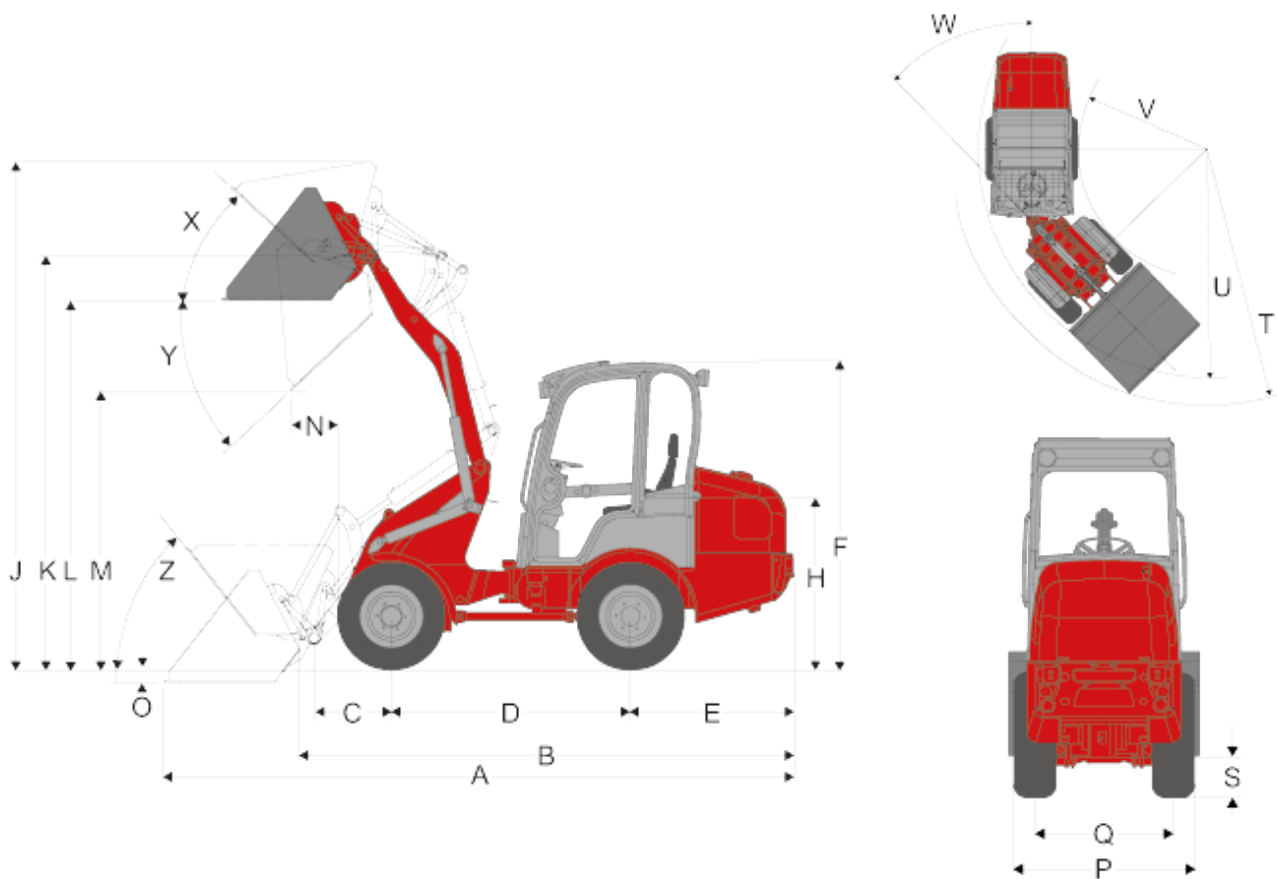
Dimensions

Standard tyres 10.0 / 75 - 15.3 AS ET80

A	Total length	4,420 mm	4,581 mm
B	Total length (without bucket)	3,520 mm	3,700 mm
C	Axle middle to bucket pivot pin	560 mm	720 mm
D	Wheelbase	1,732 mm	1,732 mm
E	Rear overhang	1,182 mm	1,182 mm
F	Height to top of overhead guard fixed	2,260 mm	2,260 mm
	Height to top of overhead guard foldable (eps)	2,370 mm	2,370 mm
	Height to top of overhead guard foldable, folded (eps)	1,850 mm	1,850 mm



	Height to top of cabin	2,280 mm	2,280 mm
H	Seat top height	1,280 mm	1,280 mm
J	Total working height	3,659 mm	3,830 mm
K	Height of bucket pivot (max.)	3,010 mm	3,203 mm
L	Load-over height	2,690 mm	2,880 mm
M	Dumping height	2,130 mm	2,380 mm
N	Operating distance for M	250 mm	410 mm
O	Digging depth	83 mm	130 mm
P	Total width	1,040 mm	1,040 mm
Q	Track width	780 mm	780 mm
S	Ground clearance	250 mm	250 mm
T	Maximum radius external	3,040 mm	3,120 mm
U	Radius at the outer edge	2,792 mm	2,792 mm
V	Inside turning radius	1,610 mm	1,610 mm
W	Inclination angle	48 °	48 °
X	Rollback angle at max. lifting height	43 °	57 °
Y	Dumping angle (max.)	42 °	37 °
Z	Rollback angle (on the ground)	51 °	50 °

**1380**

Hoftrac

Standard features

Engine

- Perkins 404 D-22 de (31.4 kW / 43 hp)

Loader unit

- P-kinematics (lift height 3010 mm)

Drive system

- Axle T94, hydrostatic medium-pressure 4 wheel drive
- Hydrostatic 4 wheel drive, travel direction can be selected via joystick
- Service brake: Hydrostatic drive system acting on all 4 wheels (wear-free)
- Central service and parking brake in the drive train acting on all 4 wheels
- Tyres 10.0/75–15.3 AS ET80

Steering system

- Hydraulic articulated pendulum steering, 12° oscillating angle

Hydraulics

- 3rd control circuit front DN12
- Hydraulic oil cooler
- Lock for control valve
- Floating position for lift and tipping cylinders

Operator's cab

- Operator's canopy with retaining system roll-over protective structure / FOPS-tested, including rear window, laterally tiltable operator's cab
- Comfort seat with safety belt, fully suspended, weight, back and horizontal adjustment
- Joystick with direction control switch and integrated touch button for differential lock
- Adjustable steering column

Other

- Work lights (2 front, 2 rear)
- Operating hour meter
- Battery isolator switch
- Fuel display
- Mechanical quickhitch system for attachments

**1380**

Hoftrac

Options

Engine

- Perkins 404 D-22 (35.7 kW / 49 hp)
- Engine pre-heater (coolant), hydraulic oil pre-heater 230 V

Loader unit

- P-kinematics (high lift height 3200 mm)
- PZ-kinematics (lift height 3203 mm)

Operator's cab

- Roof lining for operator's canopy
- Front window complete with wiper
- eps (Easy Protection System): fold-down operator's canopy
- 2-door cabin, including heater and ventilation
- Cabin plug receptacle 230 V
- Right armrest
- Air-cushioned comfort seat (artificial leather / fabric)
- Heated seat
- Radio

Lighting

- Additional work lights on load arm
- Lighting according to Road Traffic Regulations
- MEGA work lights (2 front, 2 rear)
- LED work lights (2 front, 2 rear)
- Rotating beacon

Drive system / Axles

- Axle T94, hydrostatic medium-pressure 4 wheel drive
- Axle T94, hydrostatic high-pressure 4 wheel drive
- Axle T110, hydrostatic high-pressure 4 wheel drive
- Axle PA940, planetary axle, hydrostatic high-pressure 4 wheel drive
- Differential lock 100%
- Chassis elevation (30 mm)
- Speed increase to 28 km/h
- Hand inching (creep speed controller)

Hydraulics

- Unpressurised reverse travel (front / rear)
- Work hydraulics of large pump (58.5 l/min)
- 3rd control circuit, including single latch on lever for 3rd control circuit
- 3rd comfort control circuit, including single latch on lever for 3rd control circuit
- 4th comfort control circuit, including single latch on lever for 3rd control circuit
- 4th additional control circuit, including separate control valve (operation: via separate lever)
- 4th additional control circuit, including separate control valve (operation: Via switch (1 - 0 - 2) in steering column)
- 4th control circuit (40 l/min) additionally via separate gear pump, including separate control valve



- 4th control circuit additionally via 4-way valve
- Notch for joystick, single
- Additional, rear dual-acting hydraulic connection, including separate control valve (operation: Via lever)
- Additional, rear dual-acting hydraulic connection, including separate control valve (operation: via switch)
- Also single-acting, rear hydraulic connection
- Also a dual-acting, rear hydraulic connection (operation: via lever for 3rd control circuit).
- Three-point rear receptacle, category I

Electrical connections

- Plug receptacle in front, triple-pole (single or dual function)
- Plug receptacle for rear attachments, 7-pin

Other

- Hydraulic quickhitch system for attachments
- Counterweight (floor plate 97 kg)
- Cast iron rear weight (138 kg)
- Reversing alarm
- Load-lowering valve
- Combination case with warning triangle and first-aid kit
- Switch position indicator
- Tool box
- TÜV expert's report for road travel (addendum in vehicle documentation)
- Fully automatic central lubrication unit
- Custommade paint finish
- Hand lever grease gun
- Lifting arm damping
- Self-recovery coupling
- Automatic trailer coupling
- Approval as self-propelled work machine with ball hitch
- Official approval for road use

Please note

that product availability can vary from country to country. It is possible that information / products may not be available in your country. Photos may depict options. Subject to change without notice. Errors and omissions are reserved. The contractual agreement is expressly decisive. More detailed information on engine power can be found in the operator's manual; the stated power may vary due to specific operating conditions.

Subject to alterations and errors excepted. Applicable also to illustrations.

Copyright © 2017 Weidemann GmbH.